

U9BUS

D0	179	D0
D1	180	D1
D2	181	D2
D3	182	D3
D4	185	D4
D5	186	D5
D6	187	D6
D7	190	D7
D8	191	D8
D9	192	D9
D10	193	D10
D11	194	D11
D12	195	D12
D13	196	D13
D14	197	D14
D15	198	D15
A0/NBS0	133	A0/BS0
A1/NBS2/NWR2	134	A1/BS2
A2	135	A2
A3	136	A3
A4	137	A4
A5	138	A5
A6	139	A6
A7	140	A7
A8	141	A8
A9	142	A9
A10	143	A10
A11	145	A11
A12	148	A12
A13	149	A13
A14	150	A14
A15	151	A15
A16/BA0	154	A16/BA0
A17/BA1	155	A17/BA1
A18	156	A18
A19	157	A19
A20	158	A20
A21	159	A21
A22	160	A22
RAS	176	RAS
CAS	177	CAS

AT91RM9200

U9PORT\_A

PA0	42	MISO
PA1	43	MOSI
PA2	44	SPCK
PA3	45	NPCS0
PA4	46	NPCS1
PA5	47	TXD3
PA6	48	RXD3
PA7	49	FXGK
PA8	50	FXEN
PA9	51	FX0
PA10	52	FX1
PA11	53	ECRS
PA12	54	ERX0
PA13	55	ERX1
PA14	58	ERXER
PA15	59	EMDC
PA16	60	EMDIO
PA17	61	TXD0
PA18	64	RXD0
PA19	65	IC
PA20	66	PX11
PA21	67	PX01
PA22	68	RXD2
PA23	69	TXD2
PA24	70	12MHZ
PA25	71	IC3_SDA
PA26	72	IC3_SCL
PA27	73	MCCK
PA28	74	MCCDA
PA29	77	MCCDA0
PA30	78	DRXD
PA31/BMS	79	DTXD

AT91RM9200

U9PORT\_B

PB0	80	RIS3
PB1	81	CIS3
PB2	82	MCWP
PB3	83	MCD1
PB4	84	MCD2
PB5	85	MCD3
PB6	86	S_TF1
PB7	87	PIEZO
PB8	88	S_ID1
PB9	89	S_RD1
PB10	90	S_RX1
PB11	91	S_RE1
PB12	92	FX2
PB13	95	FX3
PB14	96	DDD
PB15	97	ERX2
PB16	98	ERX3
PB17	99	ERXDV
PB18	100	ECOL
PB19	101	ERXCK
PB20	102	TXD1
PB21	103	RXD1
PB22	104	DDRC
PB23	118	CANIRO
PB24	119	CIS1
PB25	120	MCCD
PB26	121	RIS1
PB27	122	PCK0
PB28	123	FIQ
PB29	124	IRQ0

AT91RM9200

U9PORT\_C

PC0	17	PORT0
PC1	18	PORT1
PC2	21	PORT2
PC3	22	PORT3
PC4	23	PORT4
PC5	24	PORT5
PC6	25	WAIT
PC7	161	CFIRO
PC8	162	HDOVRC
PC9	163	CFERNW
PC10	11	NCS4
PC11	12	NCS5
PC12	13	NCS6
PC13	14	NCS7
PC14	15	PWR_DOWN
PC15	16	PWR_SWITCH_DETECT
PC16	201	D16
PC17	202	D17
PC18	203	D18
PC19	204	D19
PC20	205	D20
PC21	206	D21
PC22	207	D22
PC23	208	D23
PC24	1	D24
PC25	2	D25
PC26	3	D26
PC27	4	D27
PC28	5	D28
PC29	6	D29
PC30	9	D30
PC31	10	D31

AT91RM9200

U9XXX

JTAGSEL	105	JTAG_SEI
TDI	106	JTAG_TDI
TDO	107	JTAG_TDO
TCK	108	JTAG_TCK
TMS	109	JTAG_TMS
NTRST	110	JTAG_TRST
NRST	115	RESET
TST0	113	
TST1	114	
HDMA	125	HDMA
HDPDA	126	HDPDA
DDM	127	DDM
DDP	128	DDP
SDA10	144	SDA10
NCS0/BFCS	166	NCS0
NCS1/SDCS	167	SDCS
NCS2	168	NCS2
NCS3/SMCS	169	NCS3
NRD/NOE/CFOE	170	OEA
NWR0/NWE/CFWE	171	WE
NWR1/NBS1/CFIOR	172	SDBS1
NWR3/NBS3/CFIOW	173	SDBS3
SDCK	174	SDCK
SDCKE	175	SDCKE
SDWE	178	SDWE

AT91RM9200

U9CLOCK

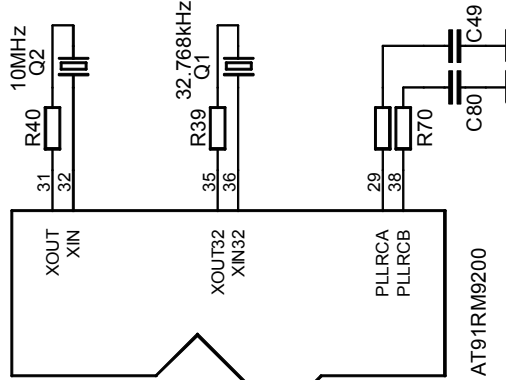

AT91RM9200

# CentiPad

HAREROD  
 Marcus Hasenstab  
 info@harerod.de

TITLE: CentiPad Programmers Model CPU

Document Number:

REV: V1.1

Date: 22.02.2006 12:25:16

Sheet: 1/14

## ConA

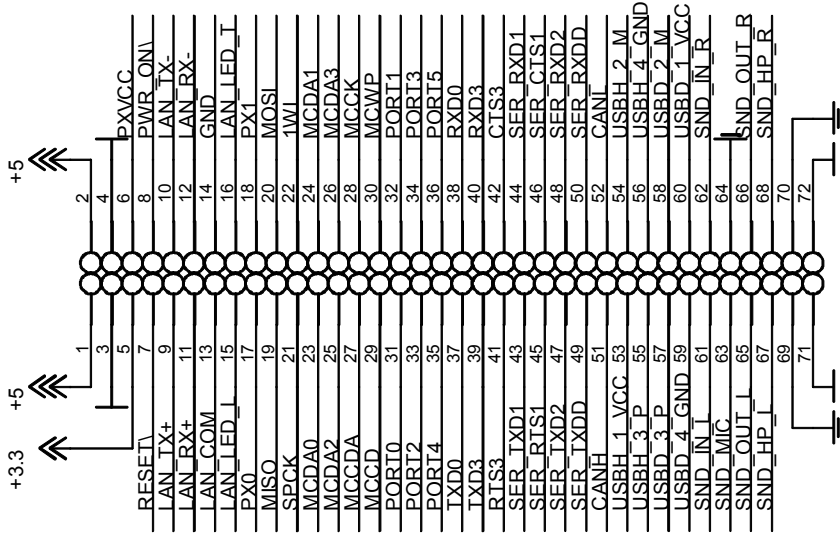

## ConB

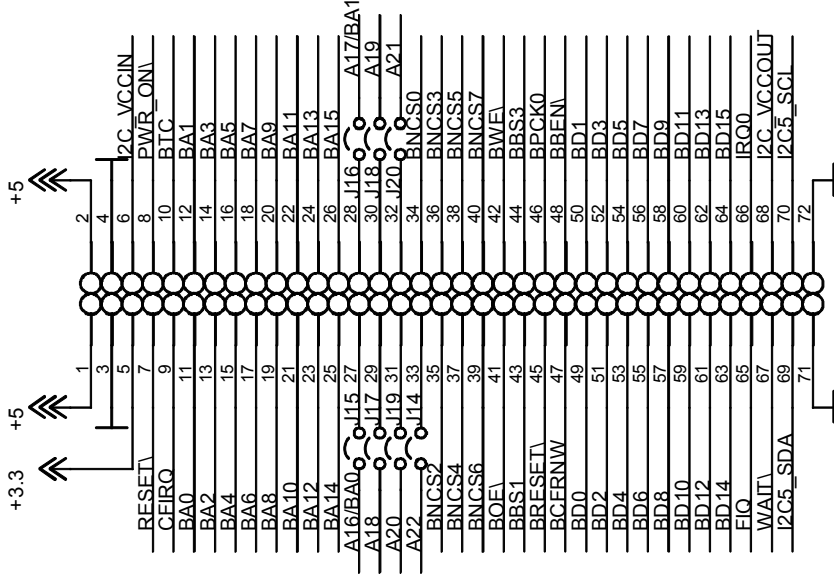

## JTAG

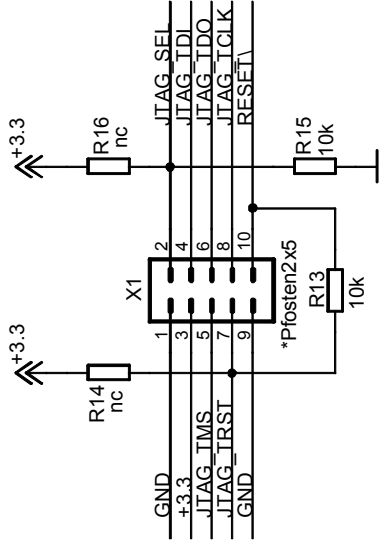

## MiniSD

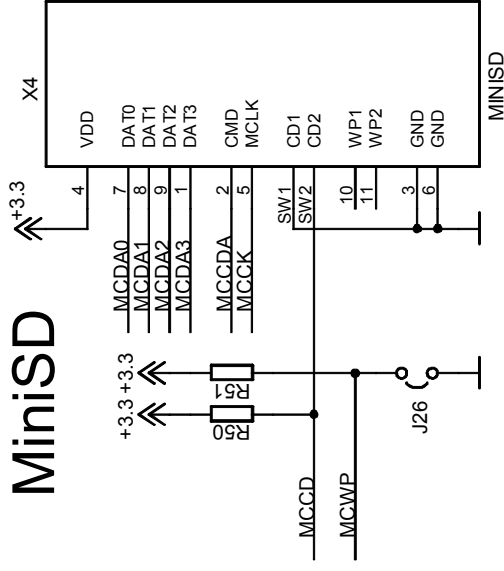

## Mouse Disco

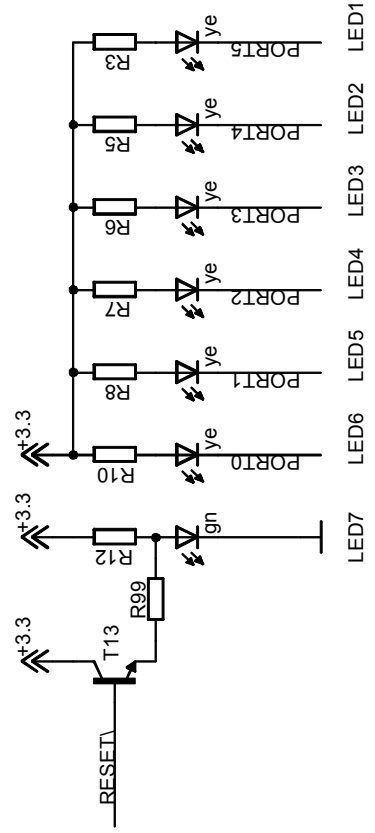

<b>CentiPad</b> HARE ROD Marcus Hasenstab info@harerod.de	
TITLE: CentiPad Programmers Model Connector	REV: V1.1
Document Number:	
Date: 22.02.2006 12:25:16	
Sheet: 2/14	

# Bus Driver

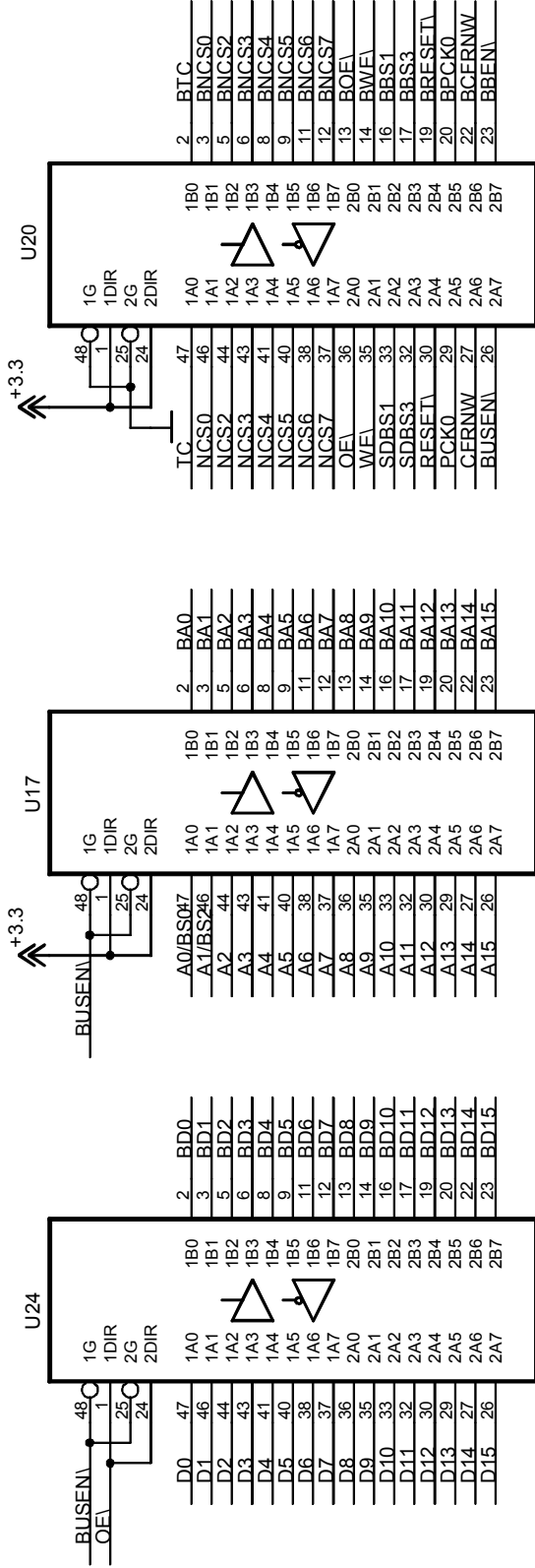

# Bus Enable

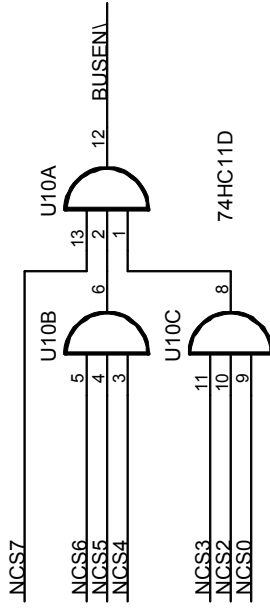
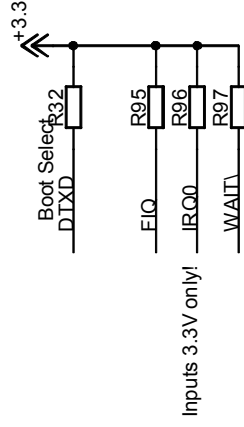

HAREROD  
 Marcus Hasenstab  
 info@harerod.de

## CentiPad

TITLE: CentiPad Programmers Mode Bus Driver

Document Number: \_\_\_\_\_

REV: V1.1

Date: 22.02.2006 12:25:16

Sheet: 3/14

# SDRAM

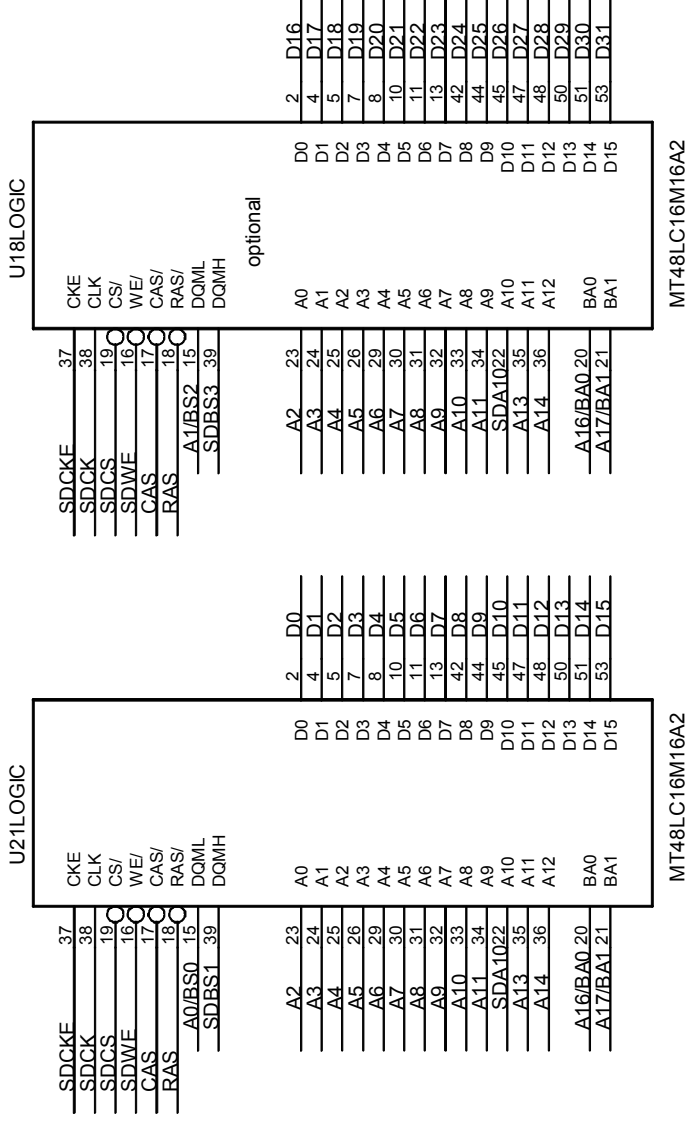

# Boot FLASH

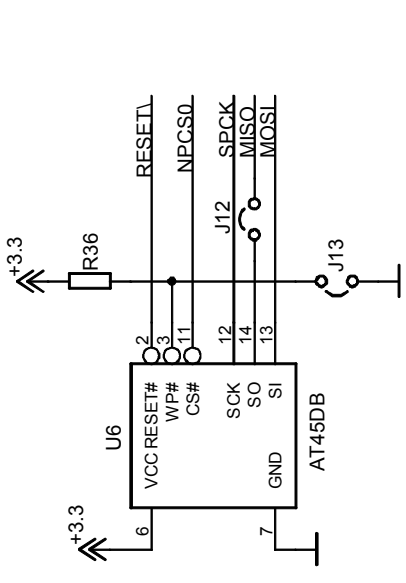

J12: Enable read/write to FLASH  
 J13: Write protect FLASH

<b>CentiPad</b>	
HAREROD Marcus Hasenstab info@harerod.de	
TITLE: CentiPad Programmers Memory, FLASH	
Document Number:	REV: V1.1
Date: 22.02.2006 12:25:16	Sheet: 4/14

# RS232 / RS422 / RS485

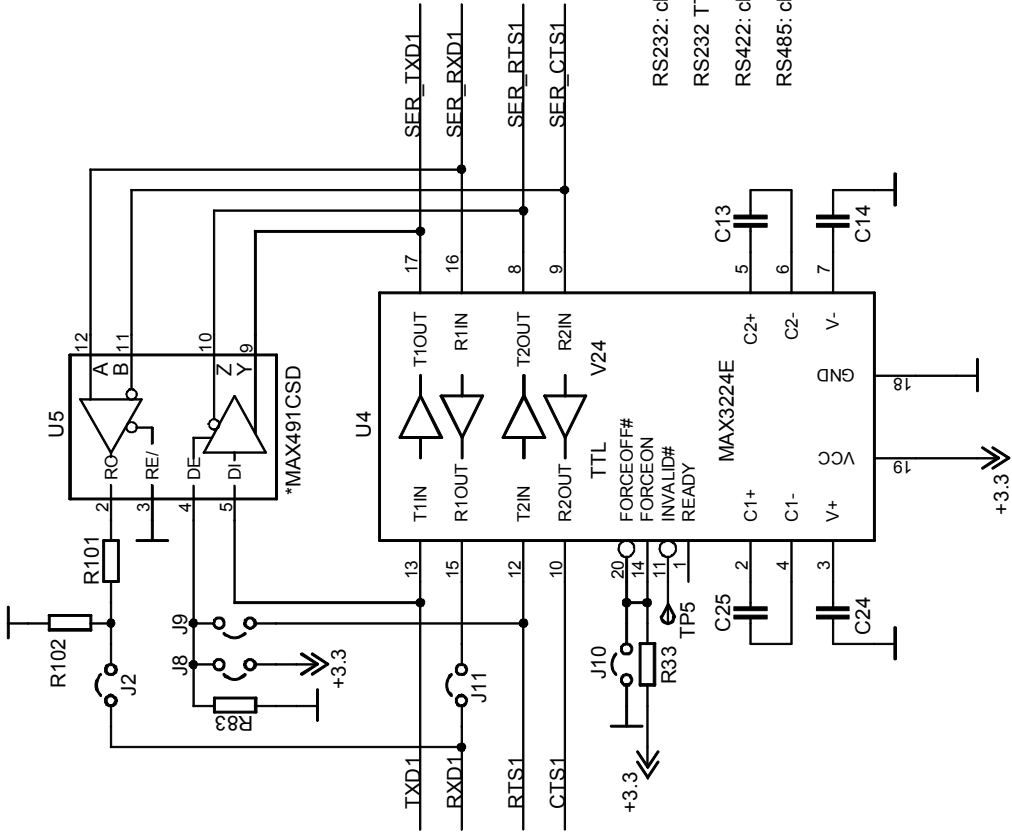

- TXD1 — J7 SER\_TXD1
- RXD1 — J1 SER\_RXD1
- RTS1 — J6 SER\_RTS1
- CTS1 — J5 SER\_CTS1

# RS232

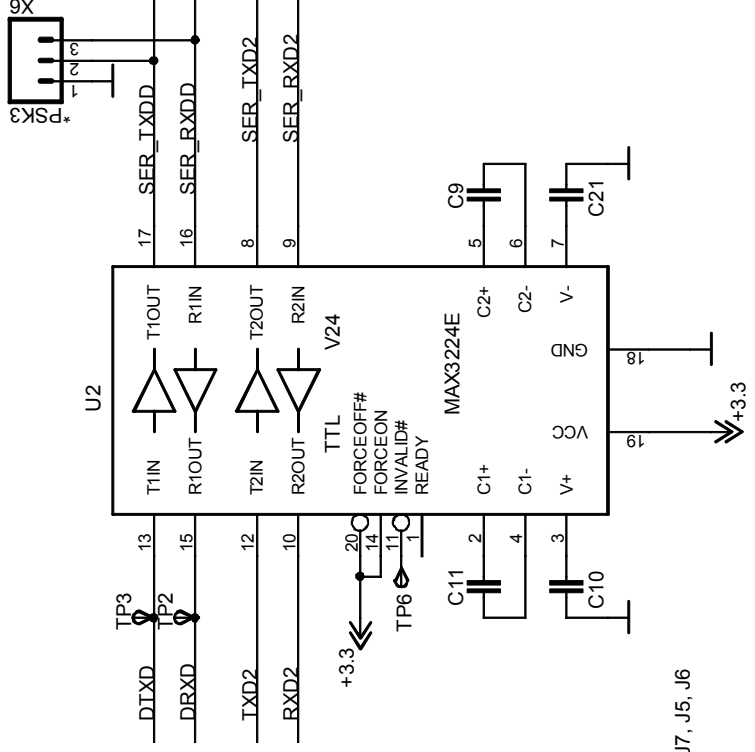

- RS232: close only J11
- RS232 TTL level: close only J1, J7, J5, J6
- RS422: close only J10, J8, J2
- RS485: close only J10, J9, J2

# CentiPad

HAREROD  
 Marcus Hasenstab  
 info@harerod.de

TITLE: CentiPad Pro ~~RS232~~, ~~RS422~~, ~~RS485~~

Document Number:  
 REV: V1.1

Date: 22.02.2006 12:25:16 Sheet: 5/14

# USB Device

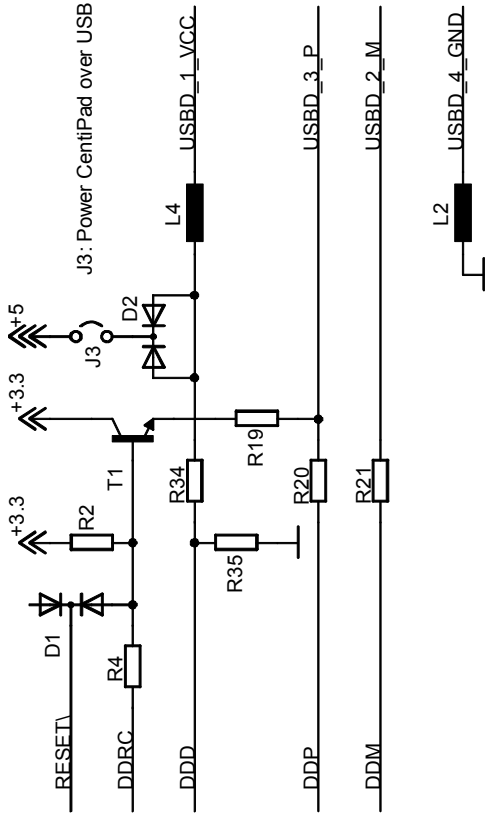

# USB Host

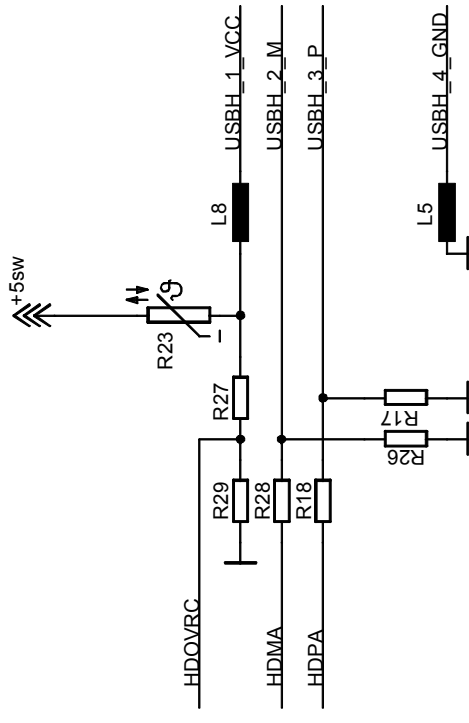

HAREROD Marcus Hasenstab info@harerod.de		USB	
TITLE: CentiPad Programmers Model		Document Number:	REV: V1.1
Date: 22.02.2006 12:25:16		Sheet: 6/14	

# LAN

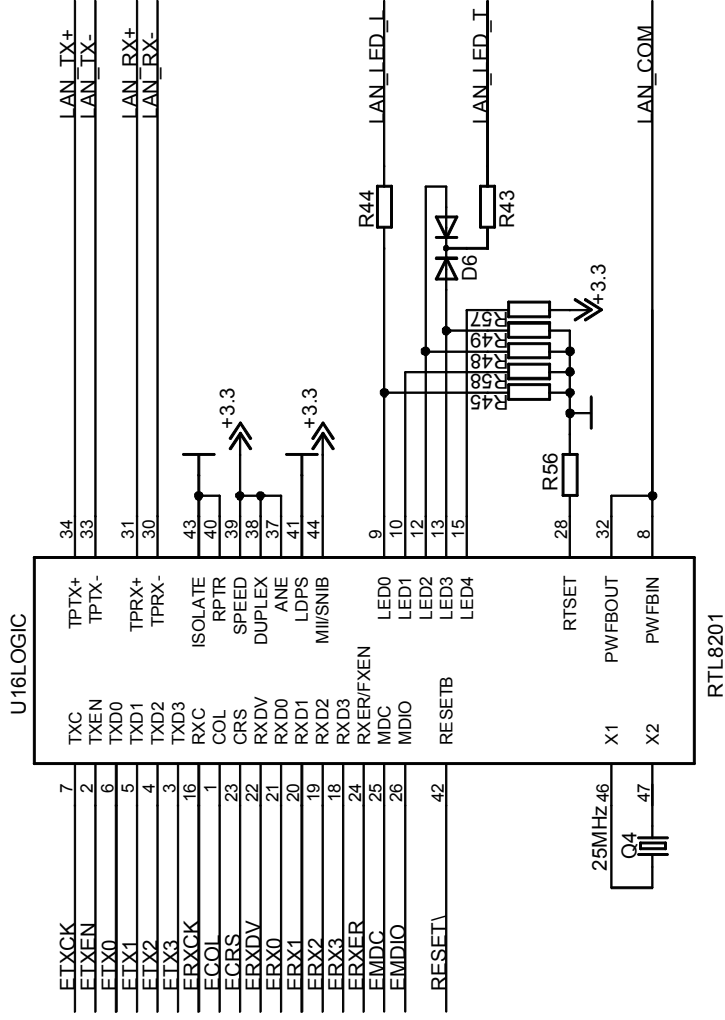

<b>CentiPad</b>		HAREROD	
TITLE: CentiPad Programmers Model		Marcus Hasenstab info@harerod.de	
Document Number:	LAN	REV:	V1.1
Date: 22.02.2006 12:25:16		Sheet: 7/14	

# TWI

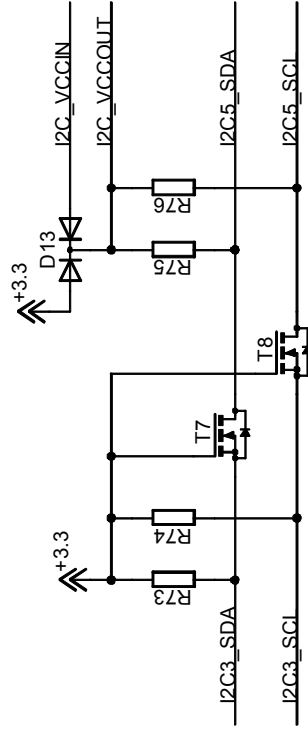

# TWI Special

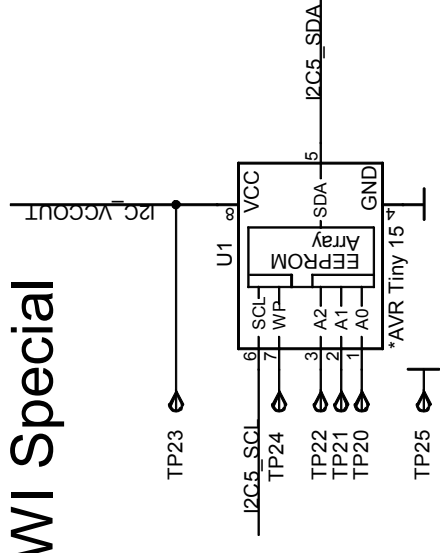

# EEPROM

8kByte

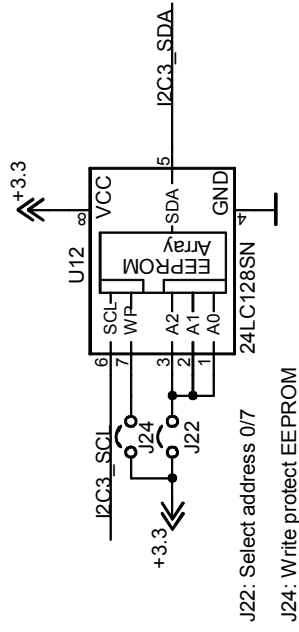

HAREROD Marcus Hasenstab info@harerod.de		I <sup>2</sup> C	
TITLE: CentiPad Programmers Model		Document Number:	REV: V1.1
Date: 22.02.2006 12:25:16		Sheet: 8/14	



# 1-Wire-Interface

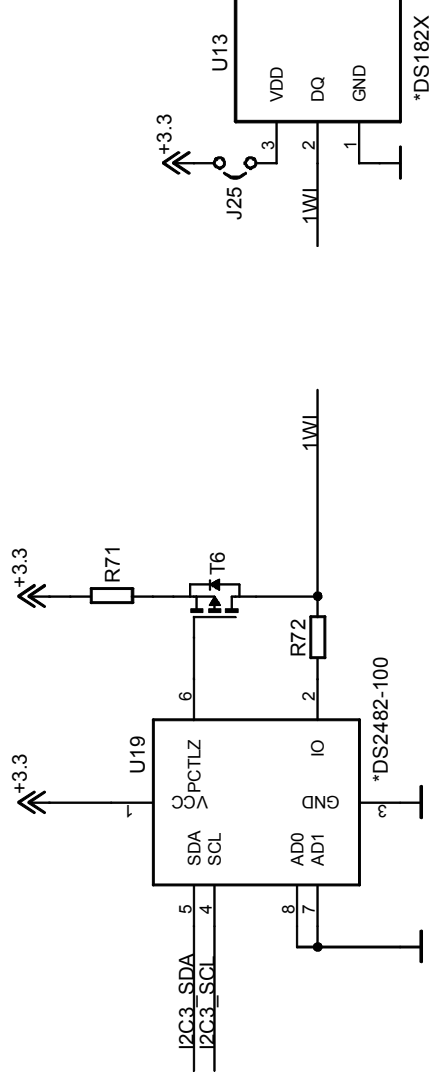

<b>CentiPad</b>		HAREROD Marcus Hasenstab info@harerod.de	
TITLE: CentiPad Programmers Model		1-Wire	
Document Number:		REV: V1.1	
Date: 22.02.2006 12:25:16		Sheet: 9/14	

\* 1-Wire is a registered trademark of Dallas Semiconductor.

# CAN

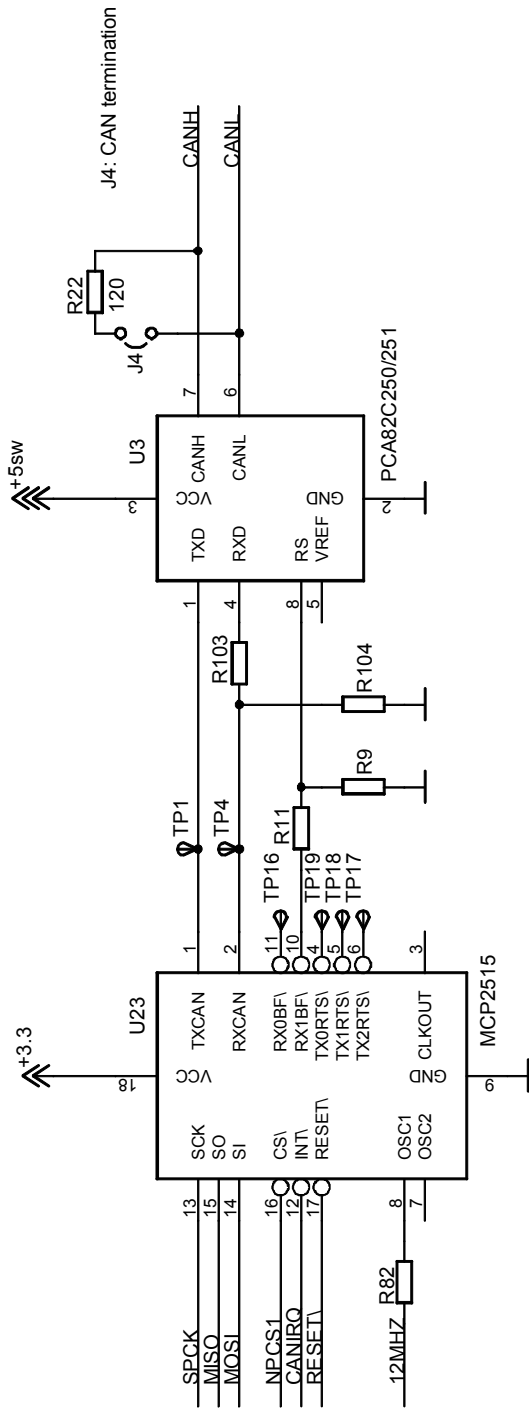

HAREROD Marcus Hasenstab info@harerod.de	
CAN	
Document Number:	REV: V1.1
Date: 22.02.2006 12:25:16	Sheet: 10/14

# Sound

U25LOGIC

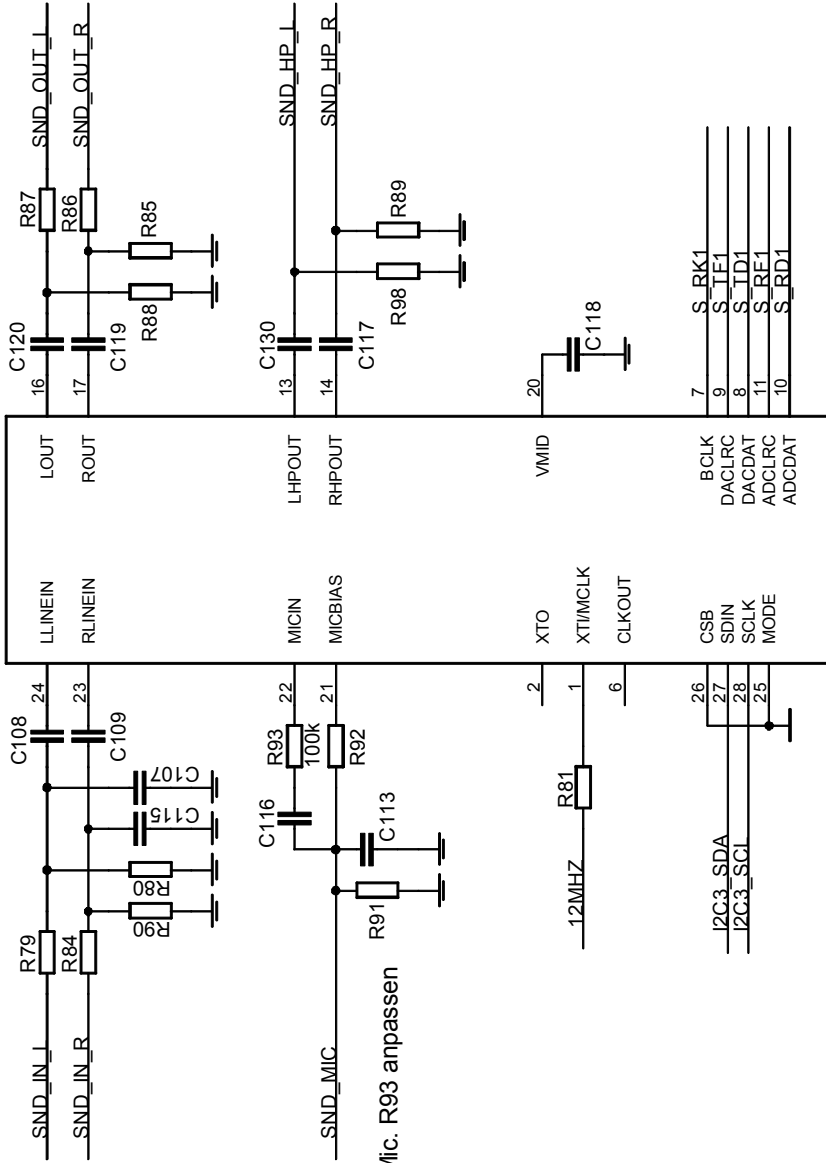

je nach Mic. R93 anpassen

WM8731

# HALDYSS

(Highly Annoying Low Dynamic Sound System)

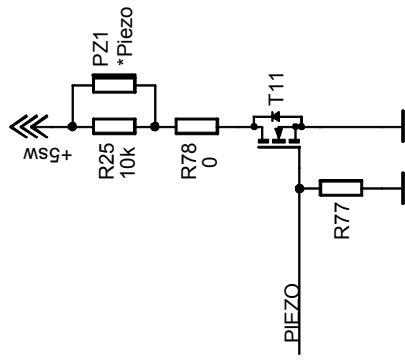

# CentiPad

HAREROD  
 Marcus Hasenstab  
 info@harerod.de

TITLE: CentiPad Programmers Model

Sound

Document Number:

REV:  
 V1.1

Date: 22.02.2006 12:25:16

Sheet: 11/14

# RTC

J23, J27: close for GoldCAP charge; open for Battery

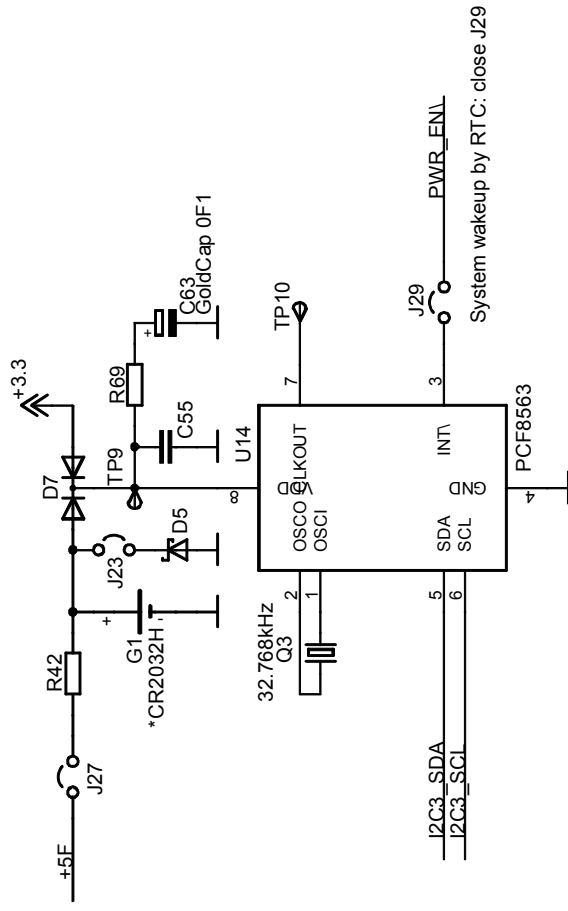

## CentiPad

HAREROD  
 Marcus Hasenstab  
 info@harerod.de

TITLE: CentiPad Programmers Model

RTC

Document Number:

REV:  
 V1.1

Date: 22.02.2006 12:25:16

Sheet: 12/14

# Power

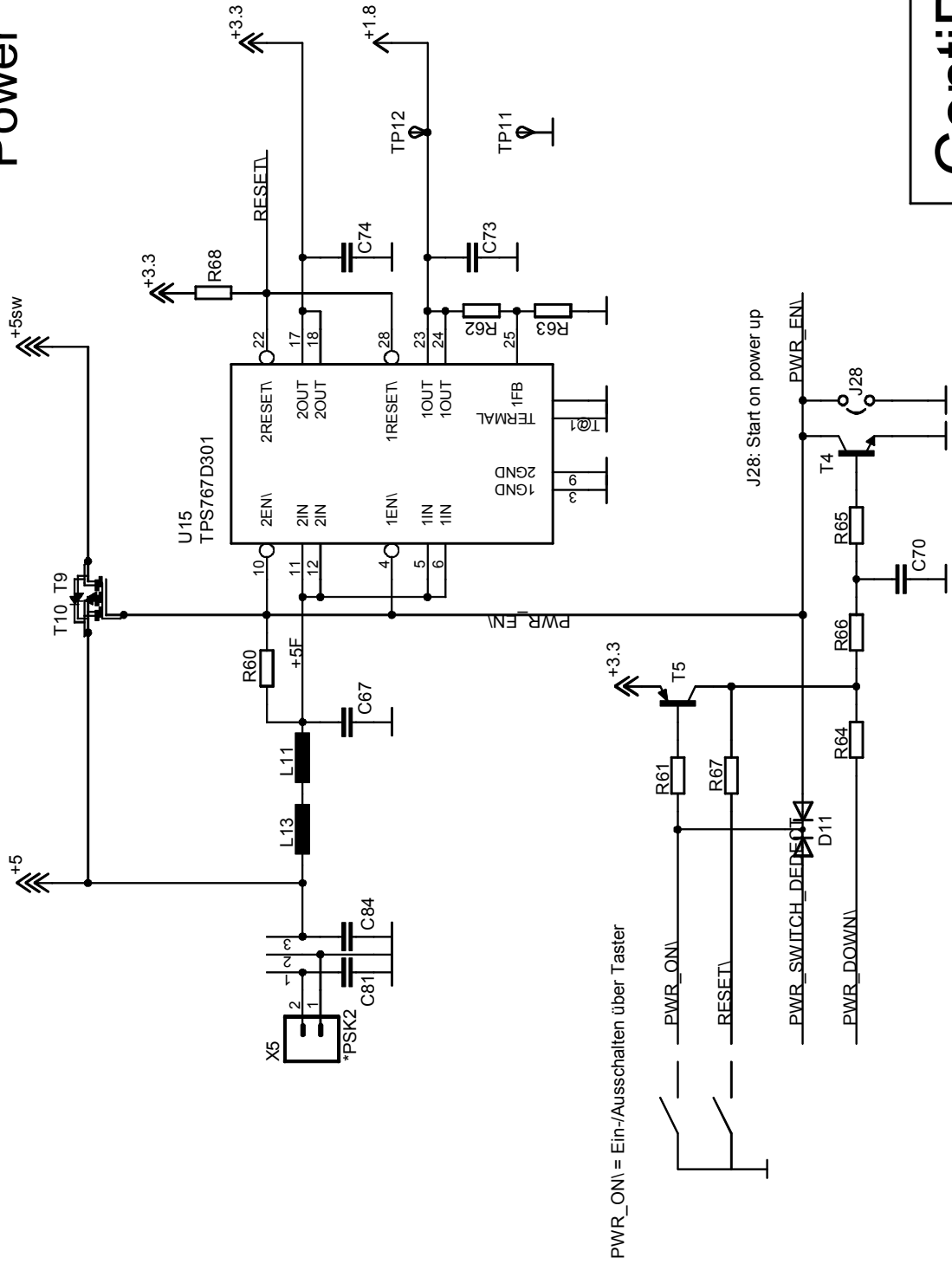

PWR\_ONI = Ein-/Ausschalten über Taster

## CentiPad

HAREROD  
 Marcus Hasenstab  
 info@harerod.de

TITLE: CentiPad Programmier, StartUp Logic

Document Number:  
 REV: V1.1

Date: 22.02.2006 12:25:16  
 Sheet: 13/14

# PortX

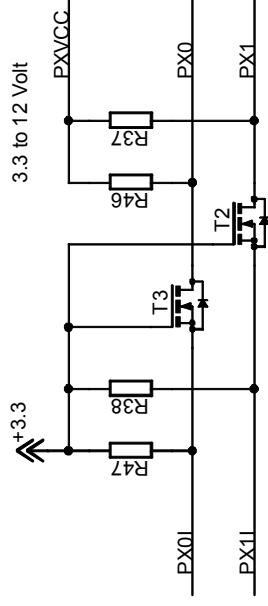

## CentiPad

HAREROD  
Marcus Hasenstab  
info@harerod.de

TITLE: CentiPad Programmers Model

PortX

Document Number:

REV:  
V1.1

Date: 22.02.2006 12:25:16

Sheet: 14/14